

NOTICE

Weight and balance or operating limitation changes shall be entered in the appropriate aircraft record. An alteration must be compatible with all previous alterations to assure continued conformity with the applicable airworthiness requirements.

8. Description of Work Accomplished

(If more space is required, attach additional sheets. Identify with aircraft nationality and registration mark and date work completed.)

USA, N3572T, 20 JANUARY 1999

- 1. Replaced original aircraft 25 amp hour, 12 volt battery with a sealed rechargeable dry power module of the following description:

Model Odyssey ES12V700 or PC625
Manufacturer Hawker Energy Products
617 North Ridgeview Drive
Warrensburg, Missouri 64093
Telephone (816)429-6437

- A. Fabricated battery bracket assembly (see figures below) from .040" 2024-T3 ALClad and attached to upper right hand firewall with eight AN 525-10 screws and appropriate nuts and washers.
- B. A piece of 10"x12"x.6125" aluminum honeycomb was added between the battery bracket and firewall for rigidity.
- C. The battery is accessible through the upper right cowling door.
- D. Static test loads were applied and meet the acceptable limits established in paragraph 2d of AC 43.13-2a.

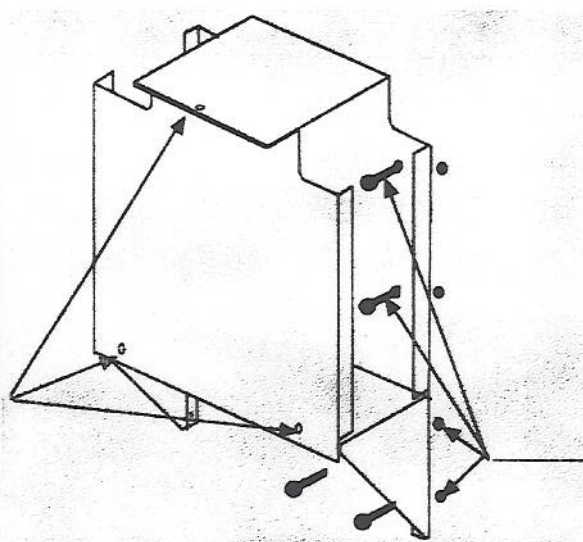
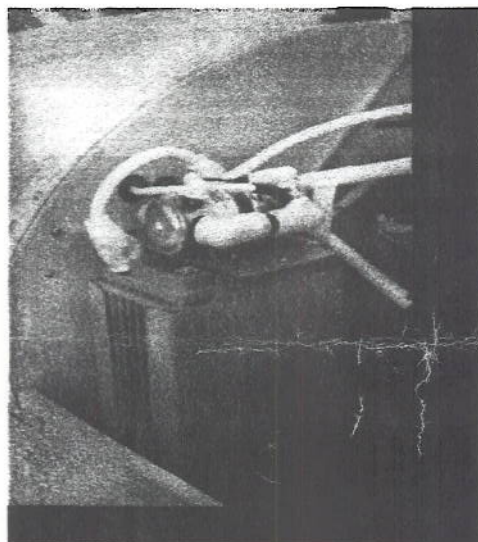

- E. Solenoids were moved from the original location in aft cargo compartment to the top of the battery bracket assembly.
- F. New cables and connectors between the battery and solenoid were used and meet the requirements of AC 43.13-2A para. 189.
- G. Continued airworthiness shall be accomplished as shown below:
Inspections shall be performed IAW CFR 14, part 43, appendix D, para. (c) (6).

Installation shall be accomplished per the following instructions:

- 1. Connect the positive (+) cable of the aircraft to the positive terminal of the battery between the two nuts – washer on top. (do not attempt to loosen the lower nut)
- 2. Connect the negative (-) cable of the aircraft to the negative terminal of the battery between the two nuts – washer on top. (do not attempt to loosen the lower nut)
- 3. Torque the top nuts to a maximum of 40 inch pounds.

Servicing: This battery is totally sealed. Never attempt to add water or electrolyte.

Charging: The charge level can be determined by using a volt meter as follows:

Volt meter reading	State of Charge	Maximum Recharge time
12.84	100%	N/A
12.48	75%	5 Hours
12.21	50%	8 Hours
11.85	25%	12 Hours

(Note: There is no current limit using a constant voltage current tapering charger.)

- H. Equipment list, weight and balance and Pilot operators handbook updated as required.

*****END*****

Additional Sheets are Attached